

<https://doi.org/10.48047/AFJBS.5.2.2023.34-47>



African Journal of Biological Sciences



Research Paper

Open Access

DEVELOPMENT OF IOT BASED WASTEWATER TREATMENT USING MICROBIAL ELECTROCHEMICAL TECHNOLOGIES

Saba Abdulkareem Mustafa^a Mohammed Ahmed Mustafa^b

Email: Saba.a.mustafa@tu.edu.iq Mohammed.ahmed.mustafa@sadiq.edu.iq

^aDepartment of Biology , College of Education for Women , University of Tikrit

^bDepartment of Medical Laboratory Technology, Imam Jaafar AL-Sadiq University, Iraq

Address of correspondence to: Mohammed Ahmed Mustafa,
Mohammed.ahmed.mustafa@sadiq.edu.iq

Article Info

Volume 5, Issue 2, April 2023

Received: 17 Feb 2023

Accepted : 08 March 2023

Published : 19 April 2023

doi: 10.48047/AFJBS.5.2.2023.34-47

Abstract:

An affordable method of producing and maintaining water that is hygienically safe, aesthetically pleasing, and appetising is known as water treatment. It is a technological intervention that removes unnecessary pollutants from water. Even if the water will be treated to the appropriate quality, the evaluation of its quality must persist after the treatment systems. The technique used to treat water is determined by the characteristics of the water sample and the intended requirements for water quality. The protection of the environment while maintaining a level of socioeconomic and global health is the main goal of wastewater treatment. Understanding the nature of wastewater is the fundamental idea that guides the creation of an efficient and advanced treatment technology to ensure the efficacy, security, and quality of the treated wastewater. Through the employment of microorganisms, microbial fuel cells (MFCs) transform chemical energy from organic substrates into electrical energy. This research makes an attempt to design an IOT system that will sense levels of humidity, temperature, and mixtures of gases, sensing each type of gas to measure its level while monitoring the changes in the above variables that occur in real-time. The main aim of this research work is to develop IoT based wastewater treatment using Microbial Electrochemical Technologies.

Keywords: Microbial Electrochemical Technologies, Internet of Things, Wastewater Treatment, Monitoring, Sensors

© 2023 Noor Ali Zayed, This is an open access article under the CC BY license (<https://creativecommons.org/licenses/by/4.0/>), which permits unrestricted use, distribution, and reproduction in any medium, provided you give appropriate credit to the original author(s) and the source, provide a link to the Creative Commons license, and indicate if changes were made

1. Introduction

One of the main goals of the United Nations' sustainable development project is access to clean water and sanitation. Around 2 billion people live in water-stressed conditions, and the globe will have a 40% water shortage by 2030, according to the UN's World Water Development Report 2021. Because of the recent surge in population and tremendous economic and technical advancement, the amount of wastewater produced globally has expanded rapidly [1, 2]. Sustainable Development Goals (SDGs) significantly emphasize improving water quality, wastewater treatment, and safe reuse. "Significantly improve water quality globally by 2030 by minimizing pollution, preventing disposal, and mitigating the leakage of hazardous compounds, halving the proportions of untreated wastewater, and massively increasing recycling and sustainable reuse" reads Target 6.3 of UN's report 2021 [1]. Wastewater management can be broadly divided into four integrated aspects: minimizing pollution, collecting, and treating wastewater as an alternative water source, retrieving valuable by-products.

The main element of the natural world and the breath of the planet is water. Planetary and solar forces pump water around the earth in its many states of gaseous, liquid, and solidity. According to the Bible, the hydrosphere is where all living things first emerged. The specific form of God's creativity is the human. Nearly all of the human organs have water contents ranging from 22% to 96%, and the human body has roughly 75% water by mass. 2 to 3 kilogramme of water must be consumed daily for an adult weighing about 75 kg to maintain normal physiological functions. About 97.20 percent of the world's 1.37 108 million ha-m of water potential has been allocated as salt water in the ocean, and 2.80 percent as fresh water. About 2.20% of the 2.8% fresh water is determined to be surface water, while 0.60 % is found to be ground water. Even of this 2.20 percent of surface water, 2.1 percent is contained in glaciers and ice caps, and just about 0.0 percent is present in lakes and reservoirs. Only 0.001% comes from streams, with the remaining 0.001% coming from water vapour in the atmosphere and 0.002% coming from soil moisture in the top 0.6 metres of soil.

At the current population growth rate of 1.91% per year, it is predicted that India's water demand will rise from its current requirement of 710 BCM to 1180 BCM by the year 2050. Additionally, it is anticipated that in the near future, the combined demand of industrial and home water would practically double. The only form of water found in nature is H₂O. Water is a universal solvent that attracts a variety of contaminants. Physical, chemical, biological, microbiological, and radioactive features are used to categorise the water pollutants.

2. Literature Review

As per Chandhini et al. (2020), they fostered an organization structure that assists with the perception of perilous gases tracked down in sewage. Assuming that the gas level surpasses the edge number, an application on the advanced mobile phone shows data about different gas ppm levels. It additionally uncovers whether working in the

climate is ok for manual scroungers [9].The advancement of a Web of Things (IoT)-based sewage level support framework was recommended by Gowthaman et al. (2018). An attractive float level sensor would be utilized to check the sewage level. The framework's engineering incorporates a sensor for sewage level location, a regulator for simply deciding, and a correspondence network for following objections about relentless sewage level ascents and, if any, blockages. It is important to keep a data set to monitor the information. The innovation sends letters and SMS-conveyed protests to the proper divisions ahead of flood as advance notice signs. [10]

Anushka et al. (2020) fostered the review which means to foster an IoT framework recognize the degrees of mugginess, temperature, and gas combinations, detecting each sort of gas to quantify its level while observing the progressions in the previously mentioned boundaries continuously. Assuming that the levels move over the limit, it will give a caution to the incorporated advanced cells of the approved people who are working remotely [11]. Priya et al. (2021) fostered a minimal expense, efficient and versatile answer for recognizing stops up and smell or horrendous scent gasses is proposed. This model utilizes a controller circuit, sensor driver circuit, microcontroller, sequential telecom innovations, and IoT module to get the necessary result from the module [12]. Samiha et al. (2021) proposed an admonition framework that utilizes GSM and IOT to pass detected information on to overseeing experts to deflect such occurrences before they affect people in general. [13].

Muhammed et al. (2020) proposed an original idea for continuous Shrewd Wastewater Observing Framework (SWMS) in Bangladesh that consequently utilizes the Web of Things (IoT). Various ventures utilize different synthetics and unrefined components and use particular creation processes. [14].A concentrate by Sharholly et al. (2007) on MSWM for Indian urban communities was directed to survey what is going on at that point and distinguish the key issues. An extensive variety of MSW treatment frameworks that have been conveyed are inspected basically alongside their advantages and disadvantages. The review is finished up with various valuable proposals that might effectively inspire the significant specialists and researchers to work further on improving the current framework. [25] According to Medvedev et al. (2015), RFID technology has some uses in product self-management, with a focus on municipal solid waste management and RFID's effects on the environment. The widespread use of RFID tags on consumer goods carries the potential of causing the dispersion of both harmful and valuable materials, as well as the disruption of current usage procedures. This results in potential medium- or long-term hazards for managing pollutants and resources. However, by using preventive principles in the early stages of RFID technology development, these hazards could be reduced or even prevented [26].

3. Methodology

The proposed procedure is Wastewater Treatment Utilizing IoT, which further develops in observing the level and stream pace of wastewater. As displayed in Figure

3.1, it comprises of IoT based checking for Microbial Electrochemical Innovation to treat wastewater.

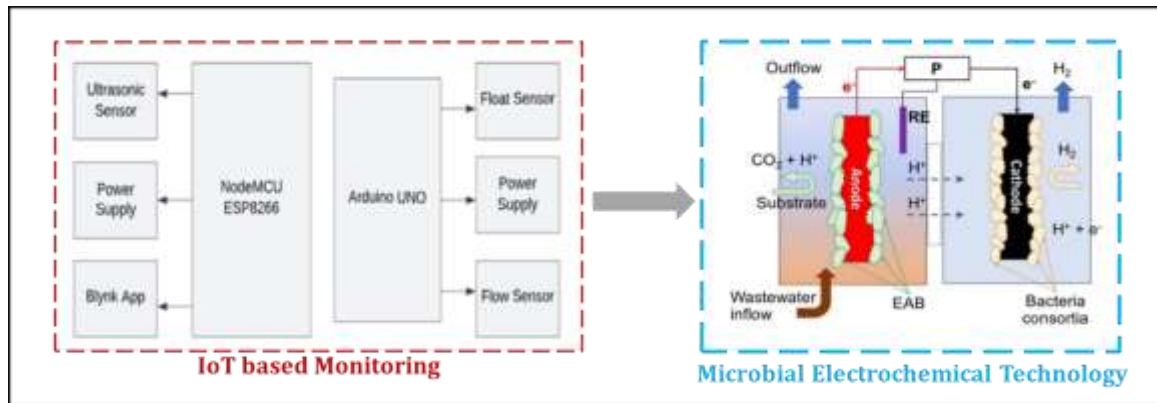

Figure 3.1 System Architecture for Proposed Methodology

3.1 IoT based Monitoring

It consists of an NodeMCU ESP2866, Arduino Uno, ultrasonic sensor, flow sensor, and float sensor. NodeMCU and Arduino will need a power supply. Node MCU will be connected to the blynk app.

3.1.1 NodeMCU Esp8266

It is an open source IoT stage with a base expense. The open-source NodeMCU microcontroller and improvement board are planned essentially for Web of Things-related purposes. In the proposed framework, it is the principal part to which the ultrasonic sensor and blynk web application are associated.

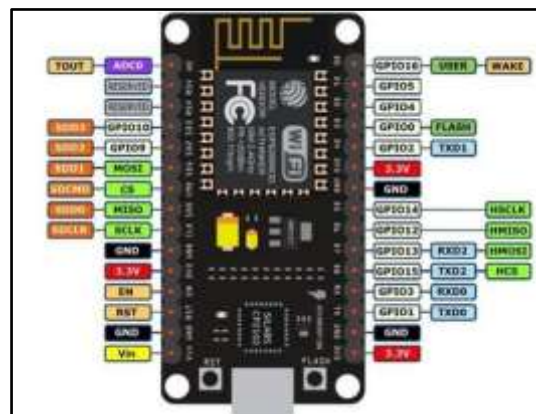

Figure 3.2 NodeMCU Esp8266

3.1.2 Arduino UNO

A variety of electronic applications can utilize this open source programmable microcontroller board since it is sensibly valued, versatile, and simple to utilize. In the proposed framework, it is one more primary part to which the stream sensor and float sensor are associated.



Figure 3.3 Arduino UNO

3.1.3 Ultrasonic Sensor

Its essential capability is to create or identify ultrasonic energy. The ultrasonic sign's electrical result is enhanced and dissected to find repeats and decide the division from a specific item. In the proposed framework it is associated with a blynk web application through hub MCU to screen the degree of sewage inside the tank.



Figure 3.4 Ultrasonic Sensors

3.1.4 Flow Sensor

An electronic device that monitors or regulates the flow rate of a fluid or a gas in a tube or pipeline is known as a flow meter. In the proposed system, a flow sensor is connected to Arduino UNO to measure the flow rate of wastewater.



Figure 3.5 Flow Sensor

3.1.5 Float Sensor

The float level sensor is a nonstop level sensor with an attractive float that goes all over as the fluid level changes. In the proposed framework, a float sensor is associated with

Arduino Uno to give a caution to clients when the degree of sewage arrives at its limit inside the tank.



Figure 3.6 Float Sensor

The ultrasonic sensor screens the degree of sewage inside the tank. A float sensor checks whether the degree of sewage inside the tank arrives at its edge or not. Also, the stream sensor breaks down wastewater stream. The sewage laborers are cautioned by a blynk at whatever point the sewage level surpasses the limit esteem, exhibiting whether cleaning the wastewater is fundamental. This framework assists in checking sewage with evening out through ultrasonic sensor and observing stream rate through stream sensor and getting notice on sewage level arriving at its limit esteem, hence helping sewage laborers to take choices for neatness and furthermore keep a solid and illness free climate.

The numerical and consistent estimations are completed inside by the ESP8266, which then, at that point, communicates the pertinent signs to the Blynk cloud for the necessary activities. Moreover, the continuous ultrasonic distance is conveyed to the Blynk application, and in case of a blockage or flood, a push notice is likewise conveyed to the cell phone.

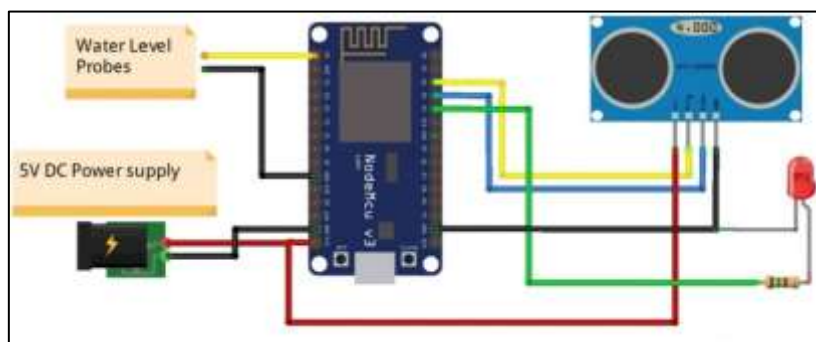

Figure 3.7 Circuit Diagram for IoT based Wastewater Treatment

As illustrated in figure 3.7, the circuit can ever be linked in accordance with the device's circuit design for detecting wastewater. The water level detectors in this example were two conductors, but float sensors could also be employed in a similar way.

Blynk is an application that is viable with both Android and iOS gadgets that permits us to utilize our cellphones to control any IoT gadget. To foster the GUI of our IoT application, we can foster the tweaked Graphical UI. You may likewise see all of the

past Blynk IoT projects that we made. To follow the sewage circumstance for this task, we will arrange our Blynk application here.

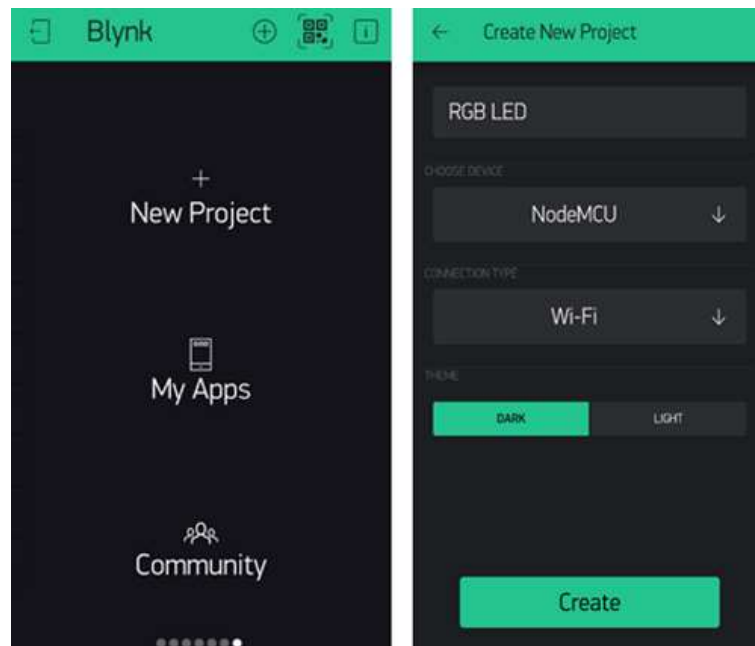

Figure 3.8 Blynk App

3.2 Microbial Electrochemical Technology (MET)

The METs are a newly developed wastewater treatment technology that decontaminates contaminated water by converting organic materials into useful renewable energy in the form of bioelectricity and other significant industrial chemicals, such as hydrogen, hydrogen peroxide, methane, alcohols, acetate, etc.[15] Utilizing METs, concurrent wastewater treatment and energy recovery is accomplished by combining microbial degradation and the electrochemical breakdown mechanism in a synergistic manner. The bio electrochemical breakdown of organics that can exchange electrons with other receptive substances/materials, such as electrodes, electron mediators, nitrate, sulphate, and insoluble metal oxides, is carried out by specialised electroactive microbes.[16].

It is referred to as a microbial electrolysis cell (MEC) whenever electrical power is utilised for increasing the electrical usage among cathode and anode instead to enable or speed up the electrode reactions. In a traditional MEC, electroactive microorganisms oxidise biological waste sources to carbon dioxide while similarly emitting protons into the resolution using a strong anode as the terminal acceptor of electrons [20]. Protons migrate to the cathode via a proton-exchange membrane that separates the two electrode divisions whereas electrons move from the anode to the cathode through an external circuit. The electrons interact with a dissolved electron acceptor at the cathode in the occurrence of an appropriate (bio)catalyst to produce the target product [17]. Similar to this, electro active bacteria can use a cathode as an electron donor to reduce substrates found in wastewater, such as NO_2 , NO_3 , SO_4 , and $\text{C}_2\text{H}_2\text{Cl}_4$ [18]. These reactions need an extra power source to enhance the voltage created by substrate

oxidation at the anode in order to enable the cathodic reaction thermodynamically efficient [19].

4. Results and Discussion

The experimental results are presented and discussed. Laboratory tests reveal the characterization of municipal sewage and water treatment plant. The experiments conducted with various parameters like pH, paddle speed, Biochemical Oxygen Demand (BOD), Chemical Oxygen Demand (COD) and Total Suspended Solids (TSS).

4.1 Estimation of Biochemical Oxygen Demand (BOD)

It measures the amount of biologically biodegradable solid waste that is contained in the water sample as well as how much oxygen the microbes need to stable that biologically degradable organic matter in an aerobic environment. 10 mL each of water sample is added in two 300 mL BOD bottle. The BOD bottles are filled with D.H₂O. One of the 300 mL BOD bottle is kept in an incubator at 20° C for 5 days and the Dissolved Oxygen analysis is done after 5 days. With the other BOD bottle 1 mL of manganese sulphate and 1 mL of alkali iodide is added and shake it by repeated inversion. The brown precipitate is allowed to settle down. Then 1 mL con sulphuric acid is added and shakes it well. 205 mL of sample from the BOD bottle is taken out in a conical flask and titration was done with N 40 sodium this sulphate using starch indicator and the end point is noted as disappearance of the blue colour.

$$\text{BOD} = (\text{Initial Dissolved Oxygen in Sample} - \text{Dissolved Oxygen after 5 Days}) \times \text{Dilution Factor} \quad (\text{Eq.4.1})$$

4.2 Estimation of Chemical Oxygen Demand (COD)

In a 250 mL refluxing flask 20 mL sample is taken. A few glasses leads and 0.2g HgSO₄ is added with the sample. 30 mL sulphuric acid is slowly with mixing to dissolve HgSO₄. The conical flask is cooled during mixing. 5 mL, 0.25N potassium dichromate (K₂C₂O₇) solution is added and mix it thoroughly. The flask is attached with the condenser and turn on cooling with water. Reflux for 1 hour. The condenser is washed with H₂O and disconnect the reflux contender. Cool to the room temperature. 2 to 3 drops of ferro in indicator are added and titrate with 0.1 N ferrous ammonium sulphates and the end point in the colour change from blue green to reddish brown. A blank is run with distilled water using the same quantity of the chemicals.

$$\text{COD in } \frac{\text{mg}}{\text{L}} = \frac{(\text{ml of titrant with sample} - \text{mL of titrant with blank}) \times \text{N of ferrous ammonium sulphate}}{\text{mL of sample} \times 1000 \times 8} \quad (\text{Eq.4.2})$$

4.3 Determination of Total Dissolved Solids (TSS)

Total solids are calculated from the wastes left while evaporating the untreated sample. The surplus left over once the purified material has evaporated is used to calculate the total dissolved solids.

$$\text{Total solids in } \frac{\text{mg}}{\text{L}} (\text{TS}) = \frac{\text{In g} \times 1000 \times 1000}{\text{Volume of sample taken in ml}} \quad (\text{Eq. 4.3})$$

$$\text{Total solids in } \frac{\text{mg}}{\text{L}} (\text{TDS}) = \frac{\text{of the dish in g} \times 1000 \times 1000}{\text{Volume of sample taken in ml}} \quad (\text{Eq. 4.4})$$

$$TSS = TS - TDS \quad (\text{Eq. 4.5})$$

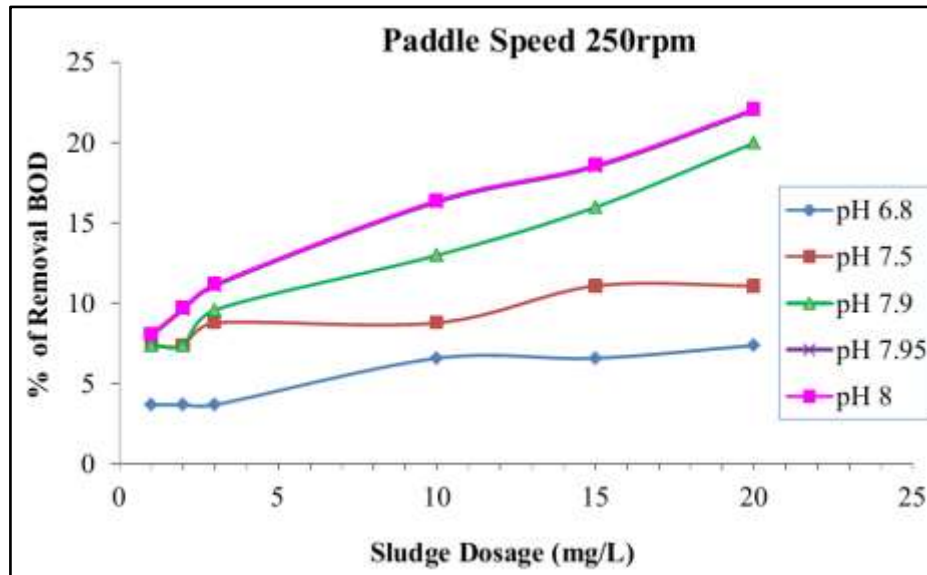

Figure 4.1. Influence of Paddle Speed 250 rpm on Removal of BOD

When the paddle speed is at 250 rpm, there is a maximum removal efficacy of BOD, COD, and TSS in the supernatant. Solution which is of 22%. This removal has been achieved at pH 7.95 and sludge loading rate of 20mg/L. pH plays an important role on the removal of suspended micro particle of the waste water system.

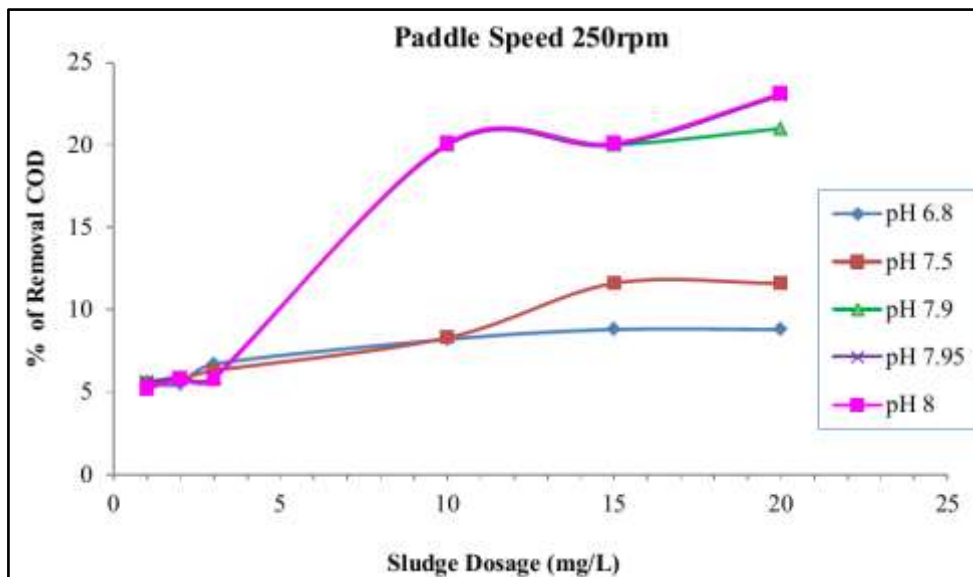

Figure 4.2. Influence of Paddle Speed 250 rpm on Removal of COD

The results of analysis of the supernatant solution of the treated water for COD at the paddle speed of 250 rpm has been presented in Figure 4.2. At pH 6.80, the percentage of COD removal starts from 5.50 % for 1mg/L sludge dosage and it reaches to 8.80 % at

20mg/L dosage and further there is no increase in the removal efficiency even beyond 20mg/L dosage.

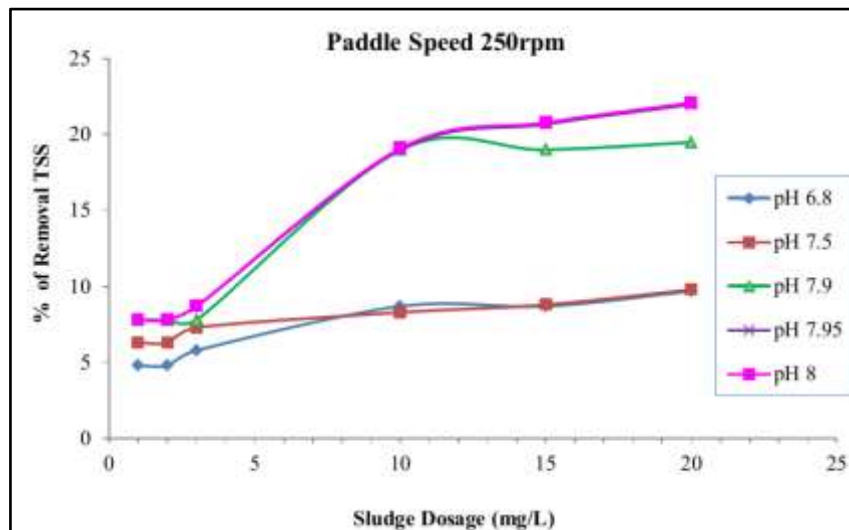

Figure 4.3. Influence of Paddle speed 250 rpm on Removal of TSS

The results of analysis of the supernatant solution of the treated waste water for TSS at the paddle speed of 250 rpm has been presented in Figure 4.3. The results imply that the removal efficiency of TSS depends on the pH factor which is maximum removal of 22.0 % at pH 7.95.

5. Conclusion

The growing interest in electrochemical processes as a possible technology to supplement, if not completely replace, existing methods for wastewater reclamation justifies in-depth research to determine the technology's true potential. The efficiency of BOD, COD, TSS removal parameters from the waste water has no considerable improvement even though, the external conditions of sludge dosing, operating speed of paddle and pH is increased. The sludge dosage in the experiment has been limited to 20 mg/L. Beyond that there is no considerable reduction in the BOD, COD and TSS. IoT sensor is used for monitoring the wastewater float sensor checks whether the level of sewage inside the tank reaches its threshold or not.

Green technology, cleaner production, carbon footprint, etc., are different concepts and principles recently considered in research work due to more and more focus on climate change and sustainable environmental development. These concepts can be considered during the development of reclamation technology and treatment procedure for Water and Wastewater. Therefore, the electrochemical processes, considered one of the sustainable techniques, uncharted advantages might be helpful in future applications in water and wastewater.

References

- [1] Ivars-Barceló F, Zuliani A, Fallah M, Mashkour M, Rahimnejad M, Luque R. Novel Applications of Microbial Fuel Cells in Sensors and Biosensors. *Applied Sciences*. 2018; 8(7):1184. <https://doi.org/10.3390/app8071184>
- [2] Kang Mao, Hua Zhang, Yuwei Pan, Zhugen Yang, Biosensors for wastewater-based epidemiology for monitoring public health, *Water Research*, Volume 191, 2021, <https://doi.org/10.1016/j.watres.2020.116787>
- [3] Abrevaya, X.C., Sacco, N.J., Bonetto, M.C., Hilding-Ohlsson, A. and Cortón, E. (2015) Analytical applications of microbial fuel cells. Part I: biochemical oxygen demand. *Biosens Bioelectron* 63, 580– 590.
- [4] Chouler, J. and Di Lorenzo, M. (2015) Water quality monitoring in developing countries; can microbial fuel cells be the answer? *Biosensors* 5, 450– 470.
- [5] Wang Z, Li D, Shi Y, Sun Y, Okeke SI, Yang L, Zhang W, Zhang Z, Shi Y, Xiao L. Recent Implementations of Hydrogel-Based Microbial Electrochemical Technologies (METs) in Sensing Applications. *Sensors*. 2023; 23(2):641. <https://doi.org/10.3390/s23020641>
- [6] Wang, J.; Zhao, S.; Kakade, A.; Kulshreshtha, S.; Liu, P.; Li, X. A Review on Microbial Electrocatalysis Systems Coupled with Membrane Bioreactor to Improve Wastewater Treatment. *Microorganisms* 2019, 7, 372.
- [7] Na Chu, Qinjun Liang, Wen Hao, Yong Jiang, Peng Liang, Raymond Jianxiong Zeng, Microbial electrochemical sensor for water biotoxicity monitoring, *Chemical Engineering Journal*, Volume 404, 2021, <https://doi.org/10.1016/j.cej.2020.127053>.
- [8] Pendharkar, Anushka & Chillapalli, Jyothi & Dhakate, Kanksha & Gogoi, Subhalaxmi & Jadhav, Yogesh. (2020). IoT based Sewage Monitoring System. *SSRN Electronic Journal*. 10.2139/ssrn.3697395.
- [9] G Chandhini, B Chithra, P Kiruthikadevi, Bhagya Sasi, V. Kamal Kumar, “IoT Based Underground Drainage Monitoring System”, *International Journal of Recent Technology and Engineering (IJRTE)* ISSN: 2277-3878 (Online), Volume-9 Issue-3 September 2020
- [10] B. Sumathy, G. Gowthaman, K. Hari Haran, G. Keerthee Rajan, A. Sweeto Jeiso, “Sewage Level Maintenance Using Iot”, *International Journal of Mechanical Engineering and Technology (IJMET)* Volume 9, Issue 2, February 2018, pp. 389–397
- [11] Anushka Pendharkar, Jyothi Chillapalli, Kanksha Dhakate, Subhalaxmi Gogoi, Yogesh Jadhav, “IoT based Sewage Monitoring System”, *Conference Paper in SSRN Electronic Journal* · October 2020
- [12] Priya Tiwari, “IoT Based Smart Sewage Monitoring System using GSM and Wi-Fi Module”, *International Journal of Innovative Science and Research Technology*, Volume 6, Issue 5, May – 2021

- [13] Samiha Sultana, Ananya Rahaman, Anita Mahmud Jhara, Akash Chandra Paul, Jia Uddin, "An IOT based Smart Drain Monitoring System with Alert Messages", 2021, DOI:10.1007/978-3-030-68452-5_9
- [14] Muhammed Sakib Hasan, Shahjalal Khandaker, Md. Shahid Iqbal, Md. Monirul Kabir, "A Real-Time Smart Wastewater Monitoring System Using IoT: Perspective of Bangladesh", 2020 2nd International Conference on Sustainable Technologies for Industry 4.0 (STI), 19-20 December.
- [15] Rony, J.H.; Karim, N.; Rouf, M.A.; Islam, M.M.; Uddin, J.; Begum, M. A Cost-Effective IoT Model for a Smart Sewerage Management System Using Sensors. J 2021, 4, 356–366. <https://doi.org/10.3390/j4030027>
- [16] Chunbo Xiu1, Liying Dong, "Design of Sewage Treatment Monitoring System Based on Internet of Things", The 31th Chinese Control and Decision Conference (2019 CCDC), 978-1-7281-0106-4/19/\$31.00 c 2019 IEEE
- [17] Chillapalli, Jyothi & Jadhav, Yogesh. (2020). IoT based Sewage Monitoring and Alert System using Raspberry PI. International Journal of Scientific Research in Computer Science, Engineering and Information Technology. 10.32628/CSEIT12064114.
- [18] M. Lizzy Nesa Bagyam, B. Raja Nithya, D. Rubikumar, S.Sangeetha , J.Santhosh, "Smart Sewage Alert System For Workers In Real-Time Applications Using Iot", International Journal of Scientific & Technology Research Volume 9, Issue 02, February 2020, ISSN 2277-8616
- [19] Tushar Pathak, Sanyogita Deshmukh, Pooja Reddy, Prof H. P. Rewatkar, "Smart Drainage Monitoring and Controlling System Using IOT", International Journal of Research in Engineering and Science (IJRES) ISSN (Online): 2320-9364, ISSN (Print): 2320-9356
- [20] Saiesh R, Prasad Ainapur, Sanil Sanjay Wadakar, Ritik Sharma, Dr. Sayed Abdulhayan, "Underground Drainage Monitoring System", Journal of Communication Engineering and Its Innovations Volume 5 Issue 1
- [21] Aditya Patel, Parth Dave, Aatish Patel, "Drainage Monitoring System Using IoT", International Journal for Research in Engineering Application & Management (IJREAM) ISSN: 2454-9150 Vol-06, Issue-08, NOV 2020, DOI: 10.35291/2454-9150.2020.0673
- [22] Gaurang Sonawane, Chetan Mahajan, Anuja Nikale, Yogita Dalvi, "Smart Real-Time Drainage Monitoring System Using Internet of Things", MAY 2018 | IRE Journals | Volume 1 Issue 11 | ISSN: 2456-8880
- [23] V. Gopalakrishnan, R. Velkennedy, A Study of the Influence of Water Treatment Plant Sludge on Waste Water Treatment, International Journal of Pharmaceutical Sciences Review and Research, 2016, ISSN 0976-044X, Volume 39, Issue (1), Pages: 325-329.
- [24] Arun, S., Sinharoy, A., Pakshirajan, K., and Lens, P. N. (2020). Algae based microbial fuel cells for wastewater treatment and recovery of value-added products. *Renew. Sustain. Energy Rev.* 132:110041. doi: 10.1016/j.rser.2020.110041

- [25] Sharholy M, Ahmad K, Mahmood G, Trivedi RC. Municipal solid waste management in Indian cities - A review. *Waste Manag.* 2008;28(2):459-67. doi:10.1016/j.wasman.2007.02.008.
- [26] Medvedev, A., Fedchenkov, P., Zaslavsky, A., Anagnostopoulos, T., Khoruzhnikov, S. (2015). Waste Management as an IoT-Enabled Service in Smart Cities. In: Balandin, S., Andreev, S., Koucheryavy, Y. (eds) *Internet of Things, Smart Spaces, and Next Generation Networks and Systems. ruSMART NEW2AN 2015* 2015. *Lecture Notes in Computer Science()*, vol 9247. Springer, Cham. https://doi.org/10.1007/978-3-319-23126-6_10
- [27] Karupusamy, S., Mustafa, M. A., Jos, B. M., Dahiya, P., Bhardwaj, R., Kanani, P., & Kumar, A. (2023). Torque control-based induction motor speed control using Anticipating Power Impulse Technique. *The International Journal of Advanced Manufacturing Technology*, 1-9.
- [28] Govindarajan, S., Mustafa, M. A., Kiyosov, S., Duong, N. D., Raju, M. N., & Gola, K. K. (2023). An optimization based feature extraction and machine learning techniques for named entity identification. *Optik*, 272, 170348.
- [29] Sudha, I., Mustafa, M. A., Suguna, R., Karupusamy, S., Ammisetty, V., Shavkatovich, S. N., ... & Kanani, P. (2023). Pulse jamming attack detection using swarm intelligence in wireless sensor networks. *Optik*, 272, 170251.
- [30] Hassan, J. A., & Rasheed, M. K. (2022, November). Synthesis and characterization of some benzimidazole derivatives from 4-methyl ortho-phenylene diamine and evaluating their effectiveness against bacteria and fungi. In *AIP Conference Proceedings* (Vol. 2394, No. 1). AIP Publishing.
- [31] Nijris, O. N., Khaleel, Z. I., Hamady, S. Y., & Mustafa, M. A. (2020). The effectiveness of Aqueous Extract of Grape Seeds *Vitis vinifera* as an antibiotic for some microorganisms and its Protective Role Histology for Liver, Kidney in Mice. *Indian Journal of Forensic Medicine & Toxicology*, 14(2), 1838-1845.
- [32] Mustafa, H. A., Majid, H. H., Abdulqader, A. T., Mustafa, M. A., & Salih, A. A. (2019). Study On Some Physiological, Biochemical And Hormonal Parameters Of Seminal Fluid Of Infertile Men. *Biochem. Cell. Arch*, 19(Supplement 1), 1943-1947.
- [33] Fadhil, K. B., Majeed, M. A. A., & Mustafa, M. A. (2019). Electronic study of fresh enzyme complexes of antifungal drugs-P450 and *Aspergillus kojic* acid biosynthesis. W: w saccharose flavus: fructose as a substratum. *Annals of Tropical Medicine and Health*, 22, 65-72.
- [34] Abdulazeez, M., Hussein, A. A., Hamdi, A. Q., & Mustafa, M. A. (2020). Estimate the Complications That Resulting from Delayed Management of Dental Trauma in Tikrit City. *Journal of Cardiovascular Disease Research*, 11(2), 80-82.
- [35] Hama Hasan, T. A., Erzaiq, Z. S., Khalaf, T. M., & Mustafa, M. A. (2020). Effect of *Equisetum Arvense* Phenolic Extract in Treatment of *Entamoeba Histolytica* Infection. *Systematic Reviews in Pharmacy*, 11(11).

- [36] Hama Hasan, T. A., Erzaiq, Z. S., Khalaf, T. M., & Mustafa, M. A. (2020). Effect of Equisetum Arvense Phenolic Extract in Treatment of Entamoeba Histolytica Infection. *Systematic Reviews in Pharmacy*, 11(11).
- [37] Nijris, O. N., Khaleel, Z. I., Hamady, S. Y., & Mustafa, M. A. (2020). The effectiveness of Aqueous Extract of Grape Seeds Vitis vinifera as an antibiotic for some microorganisms and its Protective Role Histology for Liver, Kidney in Mice. *Indian Journal of Forensic Medicine & Toxicology*, 14(2), 1838-1845.
- [38] Ali, A., Jassim, A.F., Muhsin, S.N., & Mustafa, M.A. (2020). Study of Lycium Shawii Phenolic Compounds in Treatment of Hyperlipidemia. *Journal of cardiovascular disease research*, 11, 196-199.
- [39] Ibrahim, H. M., Jumaah, L. F., Khalaf, S. A., & Mustafa, M. A. (2021). KNOWLEDGE AND PRACTICE OF BREASTFEEDING AND WEANING IN MOTHERS LIVES SAMARRA CITY, IRAQ. *Biochemical & Cellular Archives*, 21.

Cite this article as: Saba AbdulKareem Mustafa DEVELOPMENT OF IOT BASED WASTEWATER TREATMENT USING MICROBIAL ELECTROCHEMICAL TECHNOLOGIES, African Journal of Biological Sciences. 5(2), 34-47. doi: 10.48047/AFJBS.5.2.2023.34-47